



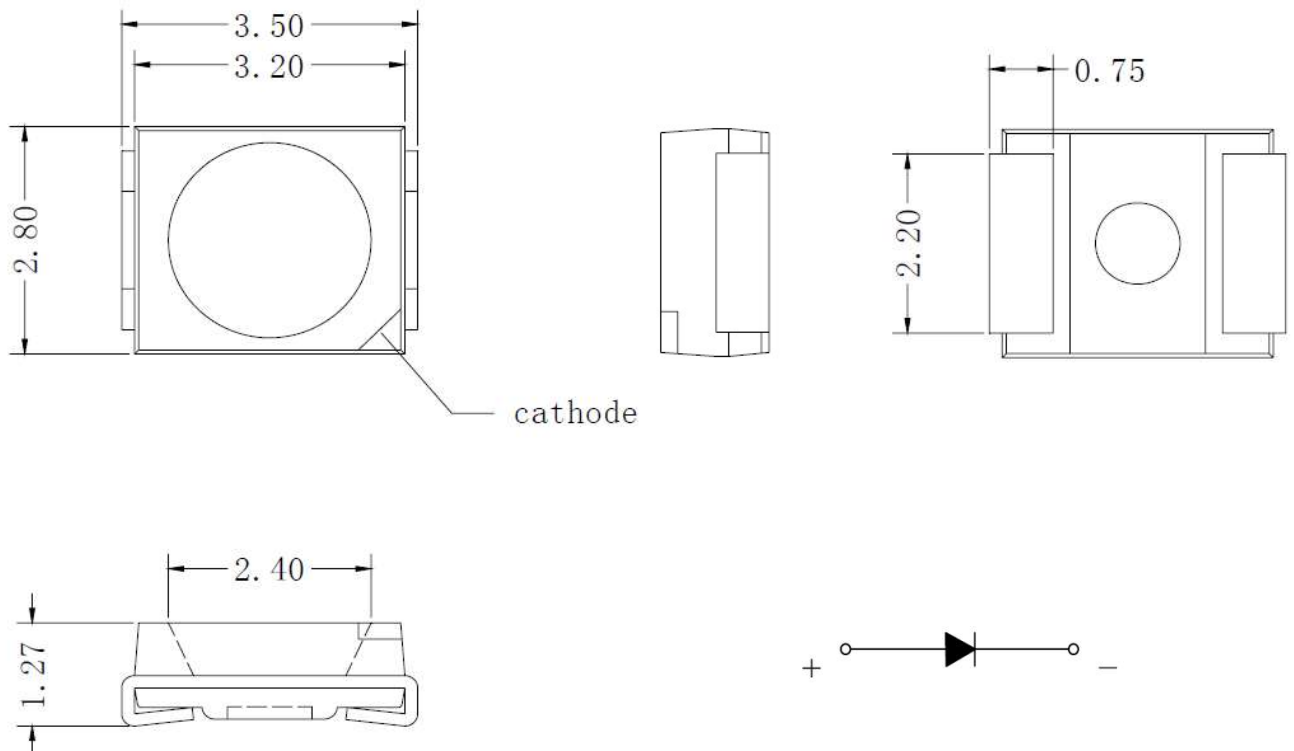
9111110000.0000 Rev.10 (17.10.19)

**Product Description**

The AR3528W LED is the small white lighting LED in 3528 package (3.5mm x 2.8mm x 1.27mm). Light-emitting diodes AR3528W have a wide range of applications and can be used as components of lighting equipment and lamps for decorative illumination of interior and architectural objects.

**Features**

- CCT: 2000K ... 20000K
- CRI Groups: 80+, 90+, 95+ (Depending on the CCT)
- Rated operating current: 20mA
- Wide viewing angle: 120°
- Luminous Flux: up to 8.3Lm.
- Efficiency: up to 150Lm/W.
- Thermal resistance,  $R_{j-s}$ : not more 150K/W.

**Package Dimensions**


Dimensions are in millimeters. Measuring tolerance:  $\pm 0.1\text{mm}$

**Absolute Maximum Ratings ( $T_s^*=25^{\circ}\text{C}$ )**

Parameter	Symbol	Value	Unit
Power dissipation	$P_D$	100	mW
DC Forward Current	$I_F$	30	mA
Peak forward current**	$I_{FP}$	50	mA
Reverse Voltage	$V_R$	5	V
ESD Sensitivity	$V_{ESD}$	1000	V
Operating Temperature	$T_{opr}$	-40...85	$^{\circ}\text{C}$
Storage Temperature	$T_{stg}$	-40...100	$^{\circ}\text{C}$
Soldering Temperature	$T_{sol}$	260 $^{\circ}\text{C}$ for 8 sec (MAX)	$^{\circ}\text{C}$

\*  $T_s$  - Solder point Temperature;

\*\* Pulse width  $\leq 0.1\text{msec}$ .

**Typical Characteristics ( $T_s=25^{\circ}\text{C}$ )**

Parameter	Symbol	Note	Min.	Typ.	Max.	Unit
Forward Voltage (Divided into 6 groups)	$V_F$	$I_F=20\text{mA}$	2.8	3.0	3.4	V
Luminous Flux	$I_V$	$I_F=20\text{mA}$	6	*	8.3	lm
Reverse Current	$I_R$	$V_R=5\text{V}$			1	$\mu\text{A}$
Viewing Angle	$2Q_{1/2}$	$I_F=20\text{mA}$		120		Deg
Saturated Red	$R_9$	$I_F=20\text{mA}$	0			-
Thermal resistance (junction to solder point)	$R_{j-s}$	-	130	135	150	K/W
Temperature coefficient of voltage	$K_{tv}$	$I_F=20\text{mA}$	-2,33	-1,75	-1,35	mV/ $^{\circ}\text{C}$

9111110000.0000 Rev.10 (17.10.19)

Optical Characteristics ( $T_s=25^{\circ}\text{C}$ ,  $I_F=20\text{mA}$ )

CRI Groups

CRI80+ Group

CCT Group* (K)	$I_F$ (mA)	CRI**			Luminous Flux , Lm		
		Min	Typ.	Max	Min	Typ.	Max
15000	20	83	85	88	6.5	7.4	8
8000	20	83	85	88	6.7	7.5	8
6000	20	83	86	88	7	7.7	8.3
5000	20	83	87	89	7	8	8.4
4000	20	83	86	89	7	7.8	8.4
3500	20	82	85	88	7	7.4	8.1
3000	20	80	83	87	7	7.6	8.2
2700	20	80	82	86	6.7	7.5	8
2400	20	78	80	84	6.5	7.4	8

CRI90+ Group

CCT Group* (K)	$I_F$ (mA)	CRI**			Luminous Flux , Lm		
		Min	Typ.	Max	Min	Typ.	Max
6000	20	90	91	94	6.5	6.7	7.5
5000	20	90	92	95	6.5	6.7	7.5
4000	20	90	94	97	6.5	6.7	7.5
3500	20	90	94	97	6	6.5	7.5
3000	20	92	95	97	6	6.4	7
2700	20	92	94	97	6	6.4	7

CRI95+ Group

CCT Group* (K)	$I_F$ (mA)	CRI**			Luminous Flux , Lm		
		Min	Typ.	Max	Min	Typ.	Max
6000	20	95	96	98	5.7	6.5	7
5000	20	95	96	98	6	6.7	7.2
4000	20	95	97	98	5.9	6.4	7.1
3500	20	95	98	98	5.5	5.9	6.3
3000	20	95	98	99	5.3	6	6.4
2700	20	95	97	99	5.2	5.7	6.3

\* - LEDs with another color temperature can be manufactured on special order.

\*\* - LEDs can be made with the following CRI: 80+; 85+; 90+; 95+; 98+ (but from the range between the minimum and maximum values).

9111110000.0000 Rev.10 (17.10.19)

**Color BIN codes**

White BINs			
CCT Group	BIN code	x	y
2400K	23D	0.4979	0.4235
		0.5035	0.4258
		0.5061	0.4193
		0.5005	0.4171
	23C	0.4923	0.4213
		0.4979	0.4235
		0.5005	0.4171
		0.4949	0.4148
	23B	0.4868	0.419
		0.4923	0.4213
		0.4949	0.4148
		0.4894	0.4126

9111110000.0000 Rev.10 (17.10.19)

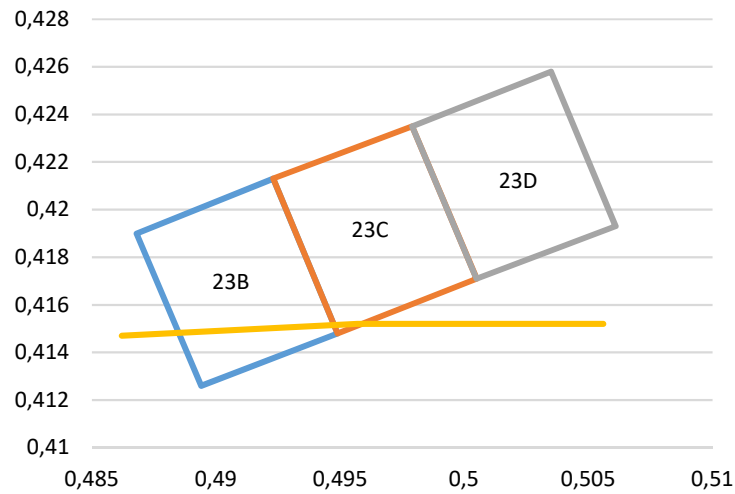
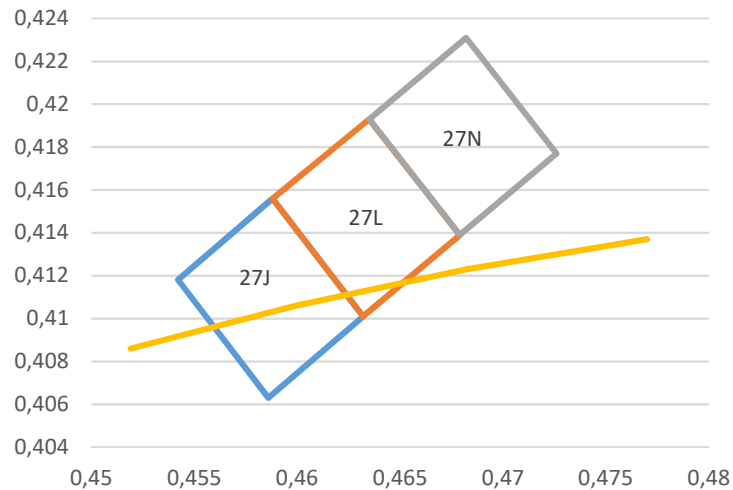


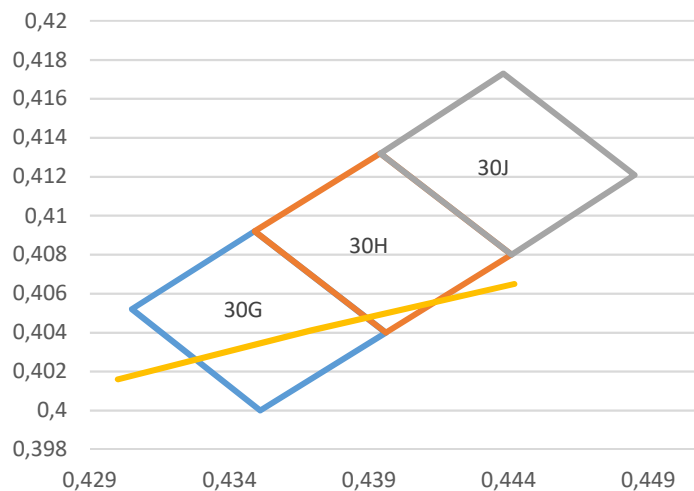
Figure 1 - 2400K BINs Coordinates

White BINs			
CCT Group	BIN code	x	y
2700K	27J	0.4586	0.4063
		0.4632	0.4101
		0.4676	0.4046
		0.463	0.4008
	27L	0.4632	0.4101
		0.4679	0.4139
		0.4723	0.4085
		0.4676	0.4046
	27N	0.4679	0.4139
		0.4726	0.4177
		0.477	0.4123
		0.4723	0.4085

9111110000.0000 Rev.10 (17.10.19)


**Figure 2 - 2700K BINs Coordinates**

White BINs			
CCT Group	BIN code	x	y
3000K	30G	0.4305	0.4052
		0.4349	0.4092
		0.4396	0.404
		0.4351	0.4
	30H	0.4349	0.4092
		0.4394	0.4132
		0.4441	0.408
		0.4396	0.404
	30J	0.4394	0.4132
		0.4438	0.4173
		0.4485	0.4121
		0.4441	0.408


**Figure 3 - 3000K BINs Coordinates**

9111110000.0000 Rev.10 (17.10.19)

White BINs			
CCT Group	BIN code	x	y
3500K	35B	0.4001	0.3914
		0.4042	0.3958
		0.4093	0.391
		0.4052	0.3866
	35C	0.4042	0.3958
		0.4083	0.4002
		0.4134	0.3954
		0.4093	0.391
	35D	0.4083	0.4002
		0.4124	0.4046
		0.4175	0.3998
		0.4134	0.3954

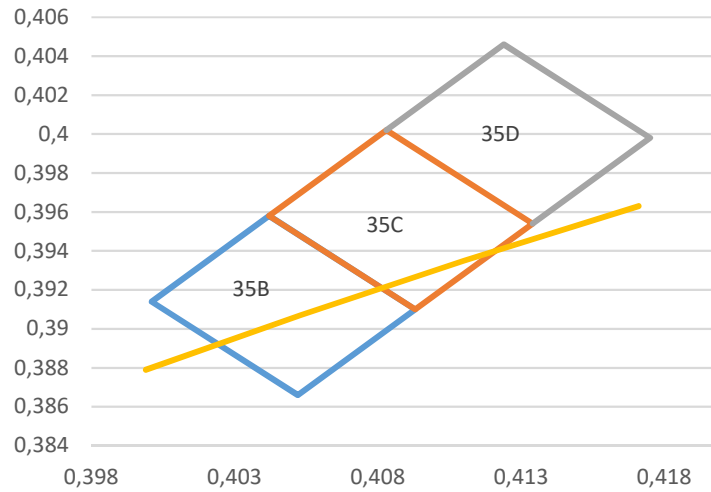
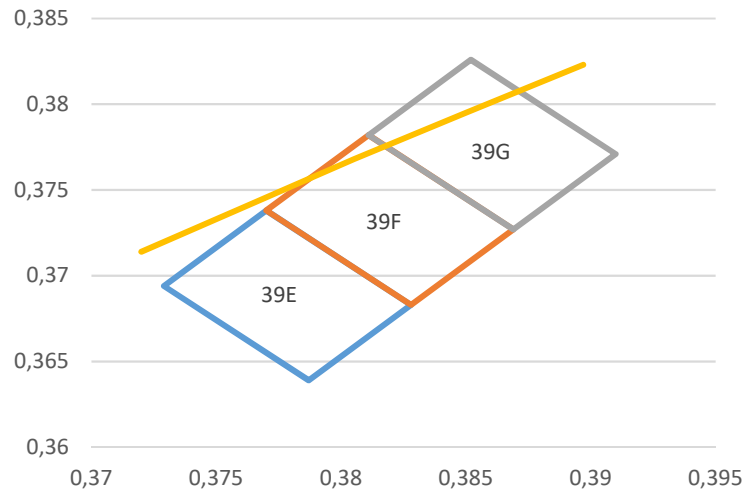


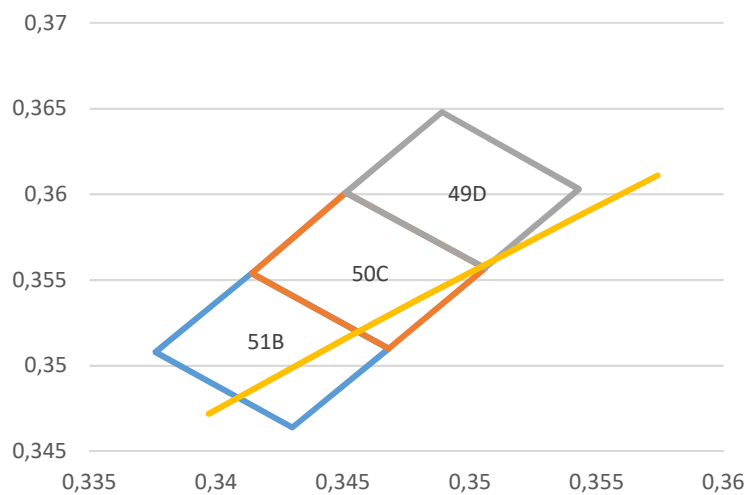
Figure 4 - 3500K BINs Coordinates

White BINs			
CCT Group	BIN code	x	y
4000K	39E	0.3729	0.3694
		0.377	0.3738
		0.3828	0.3683
		0.3787	0.3639
	39F	0.377	0.3738
		0.3811	0.3782
		0.3869	0.3727
		0.3828	0.3683
	39G	0.3811	0.3782
		0.3852	0.3826
		0.391	0.3771
		0.3869	0.3727

9111110000.0000 Rev.10 (17.10.19)


**Figure 5 - 4000K BINs Coordinates**

White BINs			
CCT Group	BIN code	x	y
5000K	51B	0.3376	0.3508
		0.3414	0.3554
		0.3468	0.351
		0.343	0.3464
	50C	0.3414	0.3554
		0.3451	0.3601
		0.3506	0.3557
		0.3468	0.351
	49D	0.3451	0.3601
		0.3489	0.3648
		0.3543	0.3603
		0.3506	0.3557


**Figure 6 - 5000K BINs Coordinates**

9111110000.0000 Rev.10 (17.10.19)

White BINs			
CCT Group	BIN code	x	y
6000K	62C	0.3135	0.3212
		0.3168	0.3261
		0.3234	0.3217
		0.3201	0.3167
	60D	0.3168	0.3261
		0.3202	0.3311
		0.3268	0.3266
		0.3234	0.3217
	58E	0.3202	0.3311
		0.3235	0.3361
		0.3302	0.3316
		0.3268	0.3266

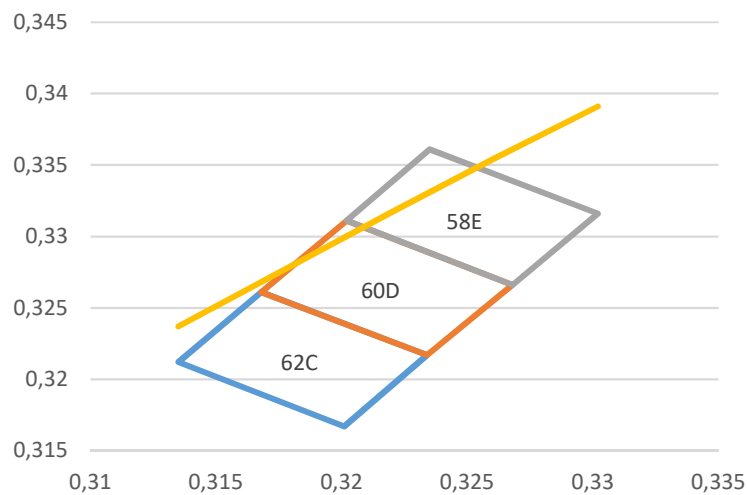
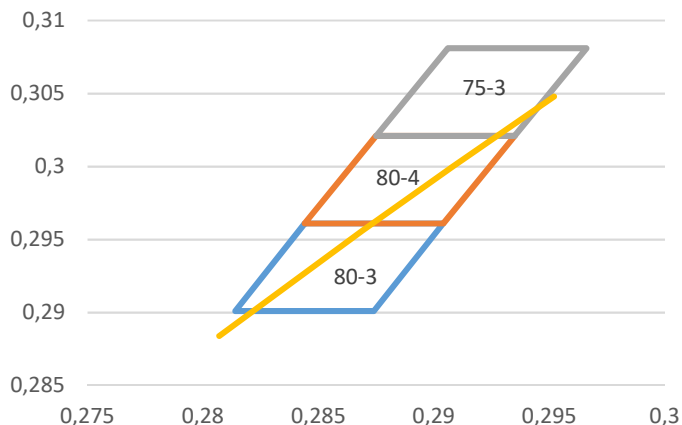


Figure 7 - 6000K BINs Coordinates

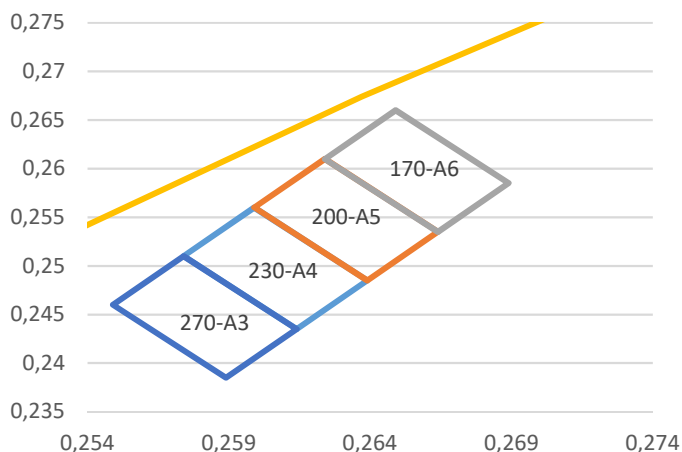
White BINs			
CCT Group	BIN code	x	y
8000K	80-3	0.2814	0.2901
		0.2844	0.2961
		0.2904	0.2961
		0.2874	0.2901
	80-4	0.2844	0.2961
		0.2875	0.3021
		0.2935	0.3021
		0.2904	0.2961
	75-3	0.2875	0.3021
		0.2906	0.3081
		0.2966	0.3081
		0.2935	0.3021



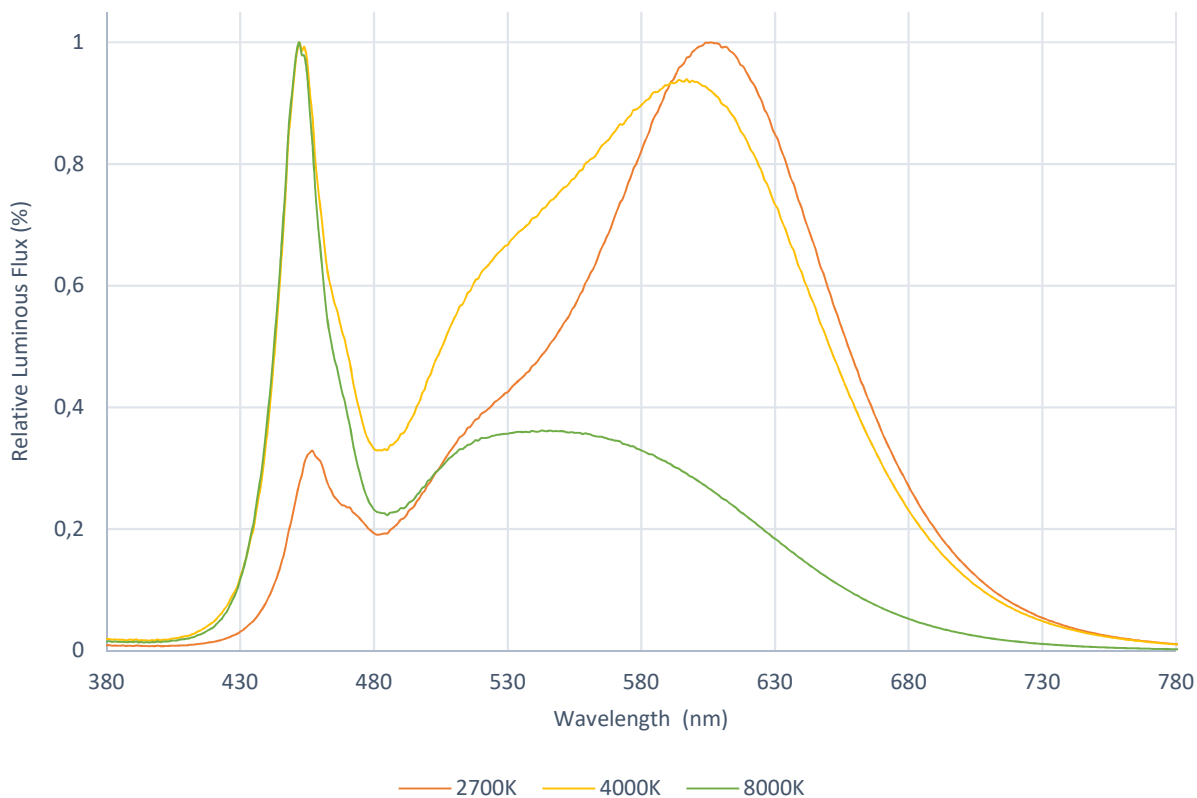
9111110000.0000 Rev.10 (17.10.19)


**Figure 8 - 8000K BINs Coordinates**

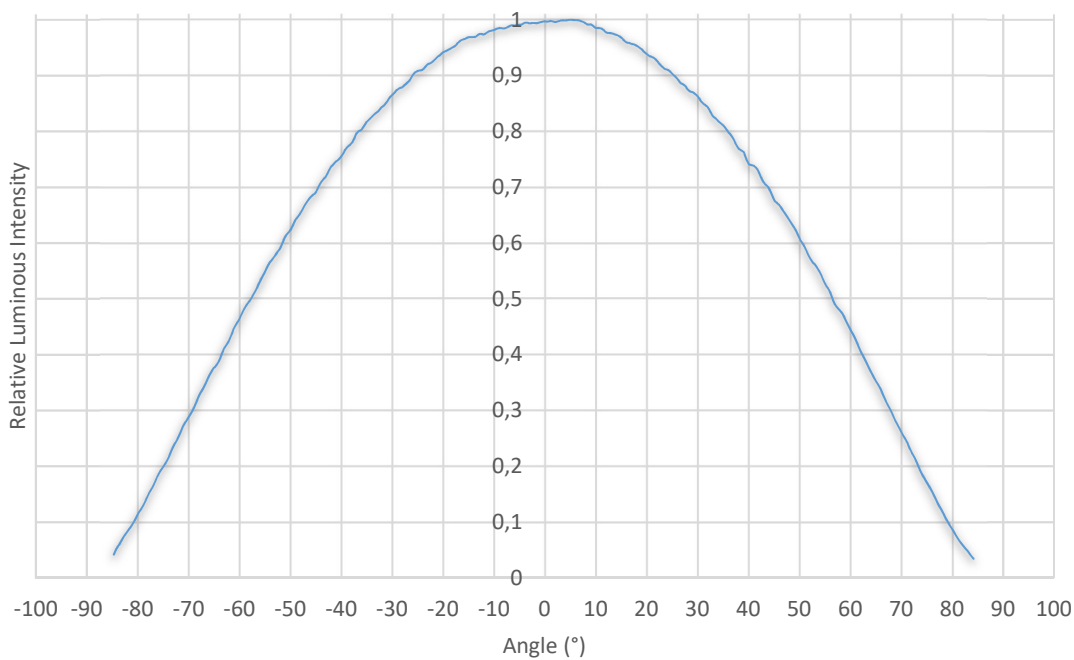
White BINs			
CCT Group	BIN code	x	y
15000K	170-A6	0.2624	0.261
		0.2649	0.266
		0.2689	0.2585
		0.2664	0.2535
	200-A5	0.2599	0.256
		0.2624	0.261
		0.2664	0.2535
	230-A4	0.2639	0.2485
		0.2574	0.251
		0.2599	0.256
		0.2639	0.2485
	270-A3	0.2614	0.2435
		0.2549	0.246
		0.2574	0.251
		0.2614	0.2435
			0.2589

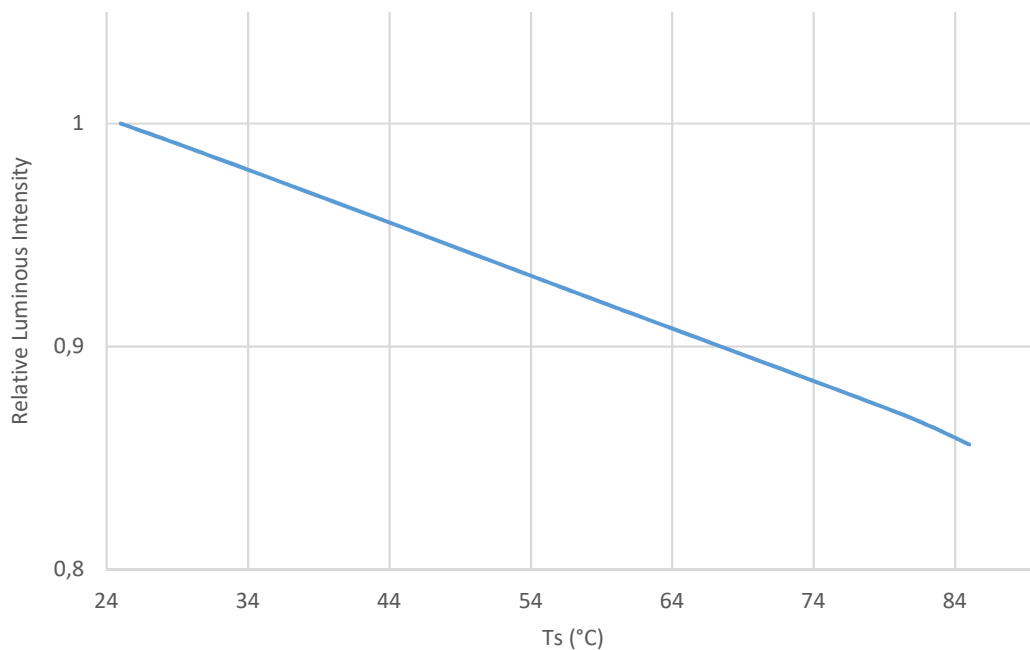

**Figure 9 - 15000K BINs Coordinates**

 Note: Tolerance of measurement of chromatic coordinates:  $\pm 0.005$

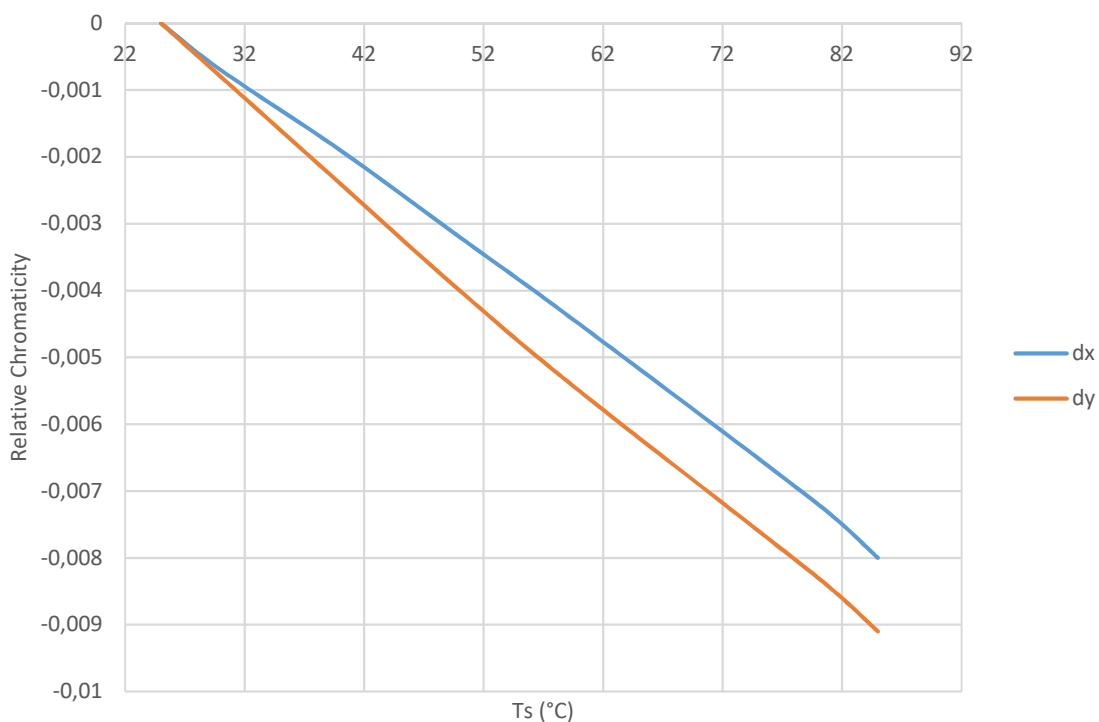
**Luminous Flux vs. Wavelength**


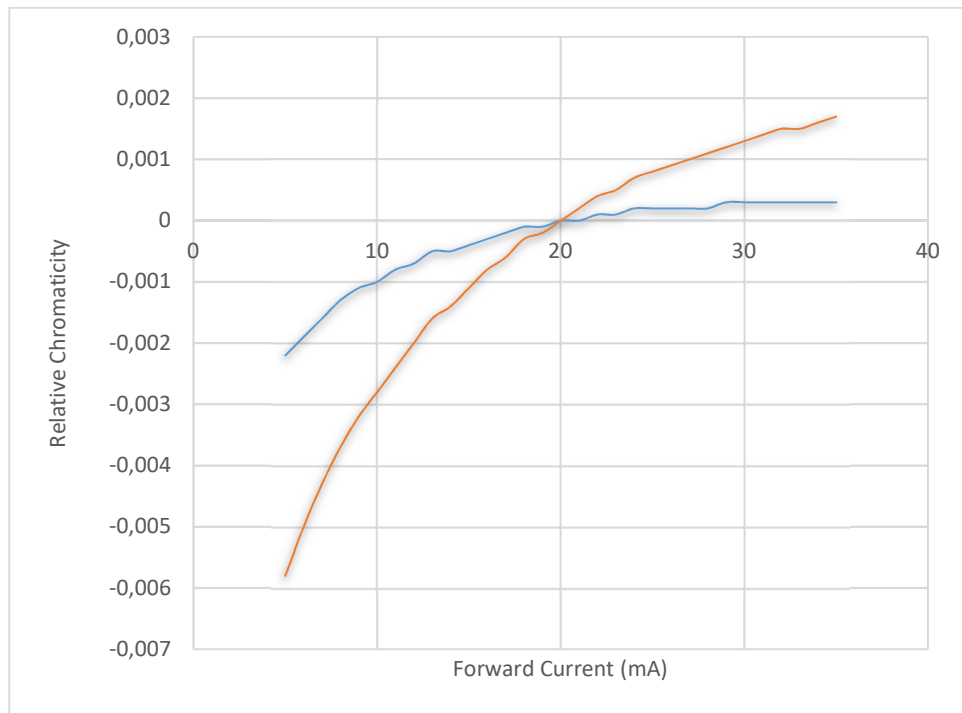
9111110000.0000 Rev.10 (17.10.19)

**Relative Luminous Intensity vs. Angle**


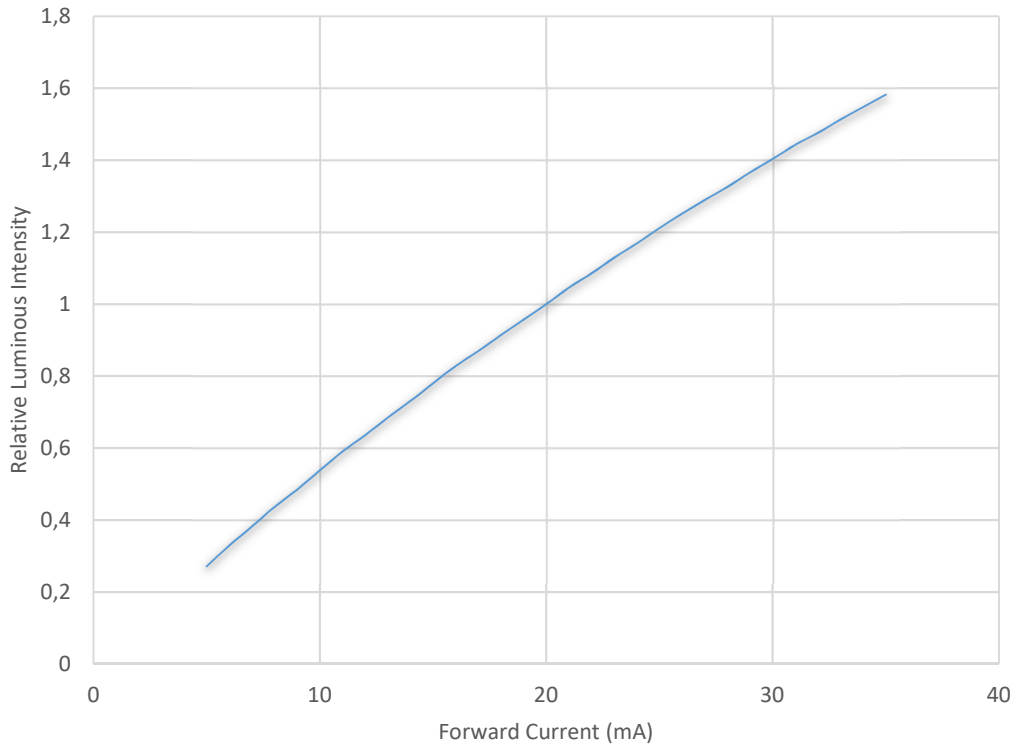
**Relative Luminous Intensity vs.  $T_s$** 


9111110000.0000 Rev.10 (17.10.19)

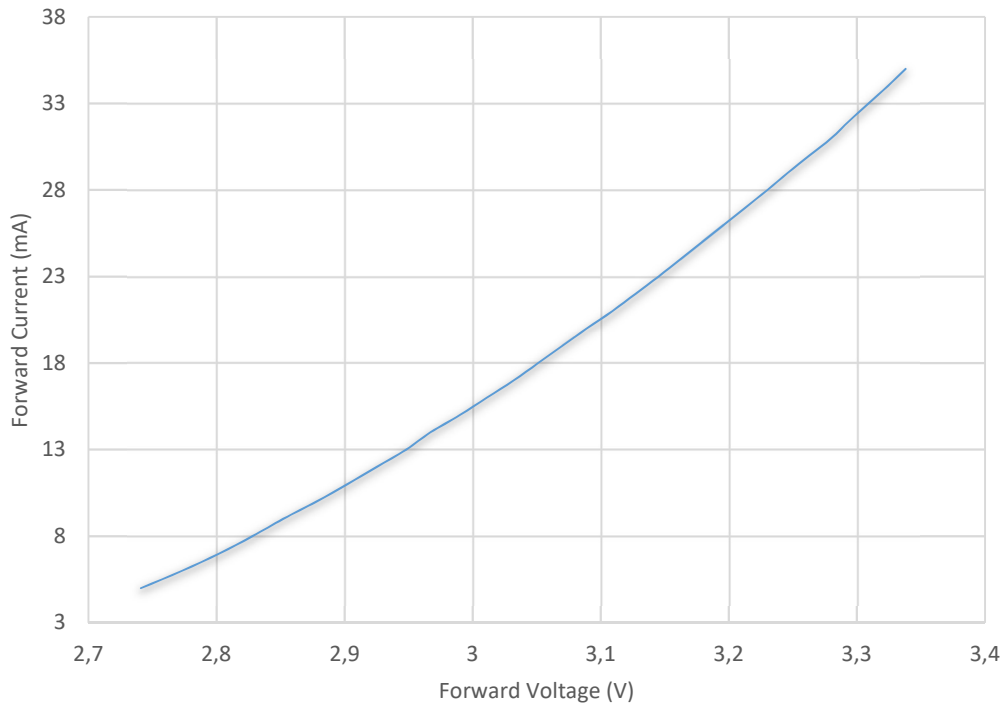
**Relative Chromaticity vs.  $T_s$  for LEDs with color temperature 4000K**


**Relative Chromaticity vs. forward Current for LEDs with color temperature 2700K**


9111110000.0000 Rev.10 (17.10.19)

**Relative Luminous Intensity vs. forward Current**


Typical electrical Characteristics for VF:3,0-3,1 at T<sub>s</sub> = 25 °C



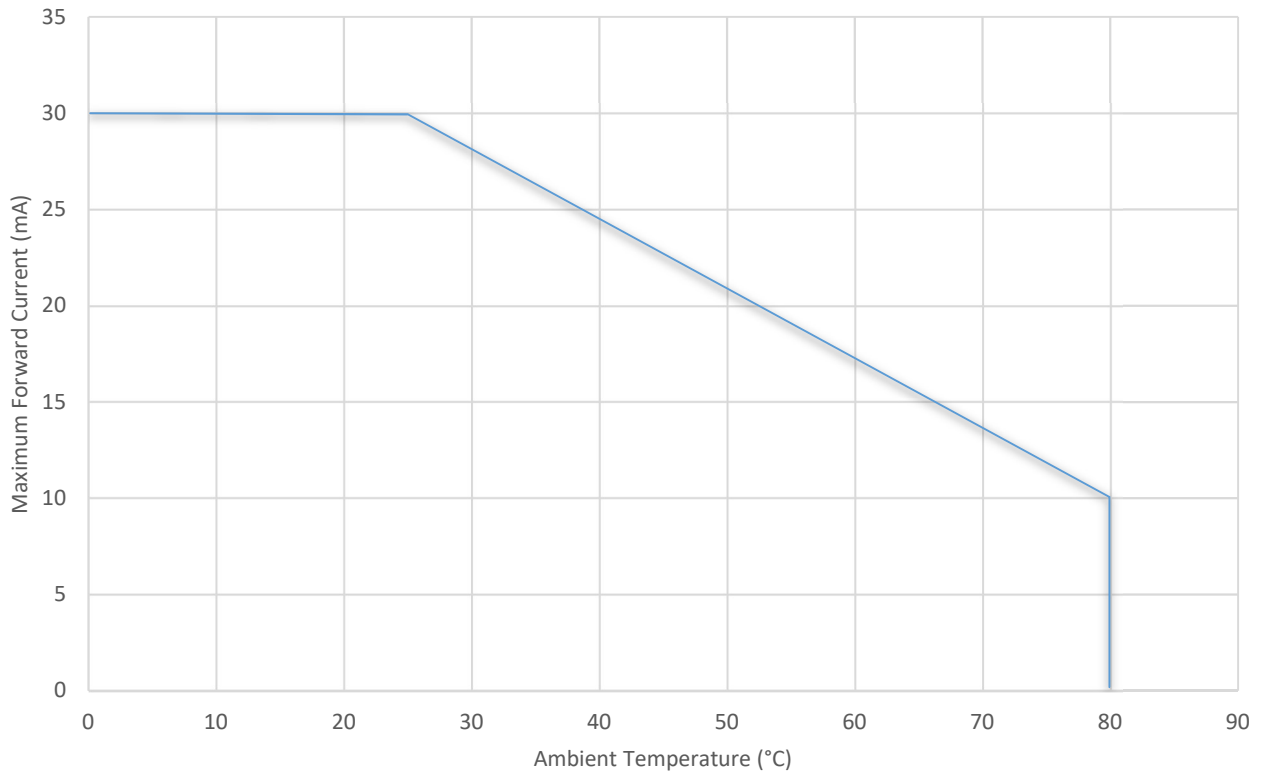
**Forward voltage groups**

Group	Min Voltage (V)	Max Voltage (V)
VF:2.8-2.9	2.8	2.9
VF:2.9-3.0	2.9	3.0
VF:3.0-3.1	3.0	3.1
VF:3.1-3.2	3.1	3.2
VF:3.2-3.3	3.2	3.3
VF:3.3-3.4	3.3	3.4

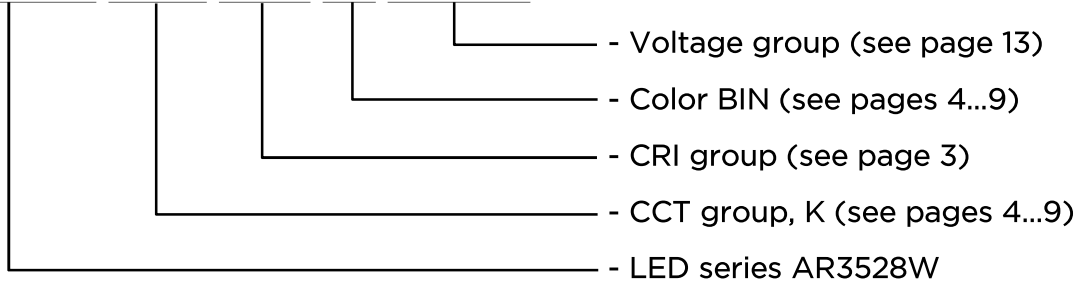
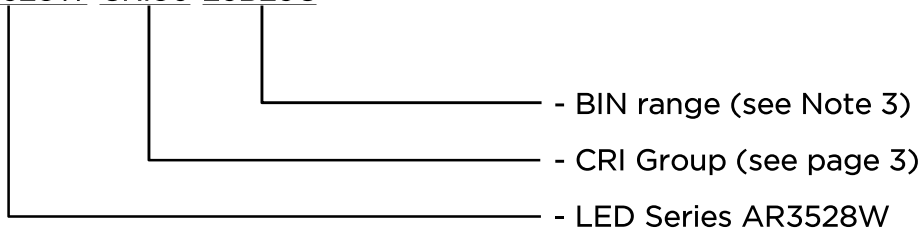
Note: Forward voltage measurement allowance is ±0.03V.

9111110000.0000 Rev.10 (17.10.19)

## Maximum Forward current derating curve vs. ambient temperature



9111110000.0000 Rev.10 (17.10.19)

**BIN and Order Code Formats**
**BIN Code Format:**
**AR3528W-2700K-CRI90-27L-VF:3.0-3.1**

**Order Code Formats:**
**Format #1 - standard order position**
**AR3528W-CRI80-23B23C**


**Note 1:** LEDs will be supplied with one of the groups of Voltage range listed on page 13.

**Note 2:** On the label of the finished product is always indicated BIN code. Order code is used only for ordering. In addition, a specific BIN code can be used for an order.

**Note 3:** Specify a BIN range corresponding to the desired color temperature or a specific BIN (see pages 4 ... 9). Examples:

**#1:** AR3528W-CRI90-62C

**#2:** AR3528W-CRI95-27L27N

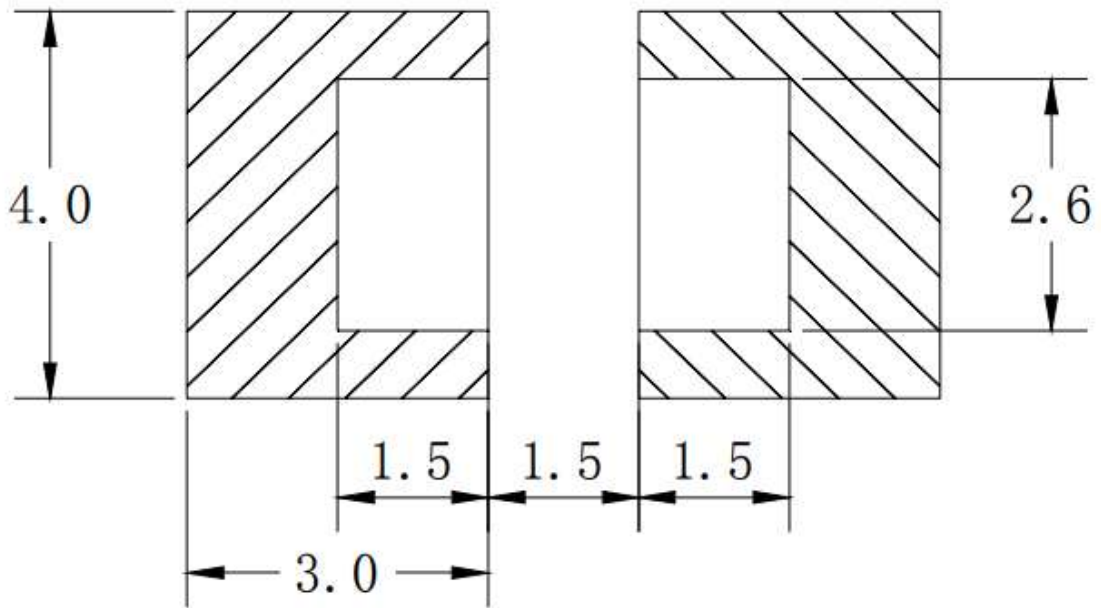
**Format #2 - custom order position**

If a LED with a color temperature not described in this document is required, then such an LED can be made to order. In this case, the order code must specify the desired color temperature lying in the range shown on page 3. The CRI value should be chosen from the range indicated on sheet 3 for the closest color temperature value. As example:

**AR3528W-CRI95-4500K**

9111110000.0000 Rev.10 (17.10.19)

## Recommended soldering pad



Dimensions are in millimeters

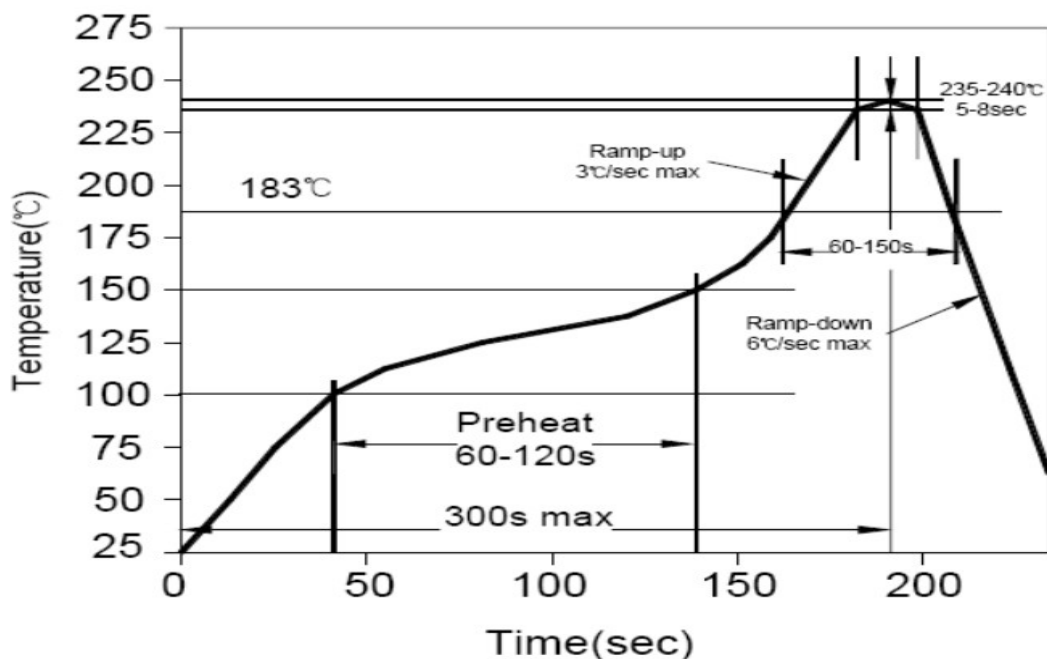
9111110000.0000 Rev.10 (17.10.19)



Soldering heat reliability

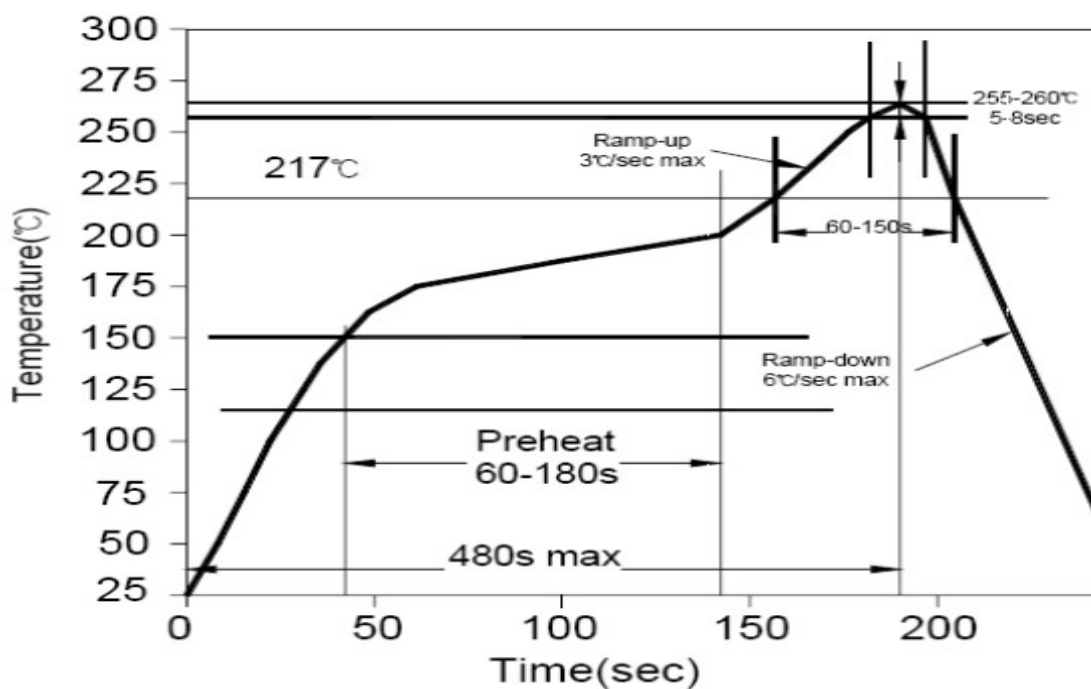
Lead solder

Classification Reflow Profile (JEDEC J-STD-020C)



Lead-Free solder

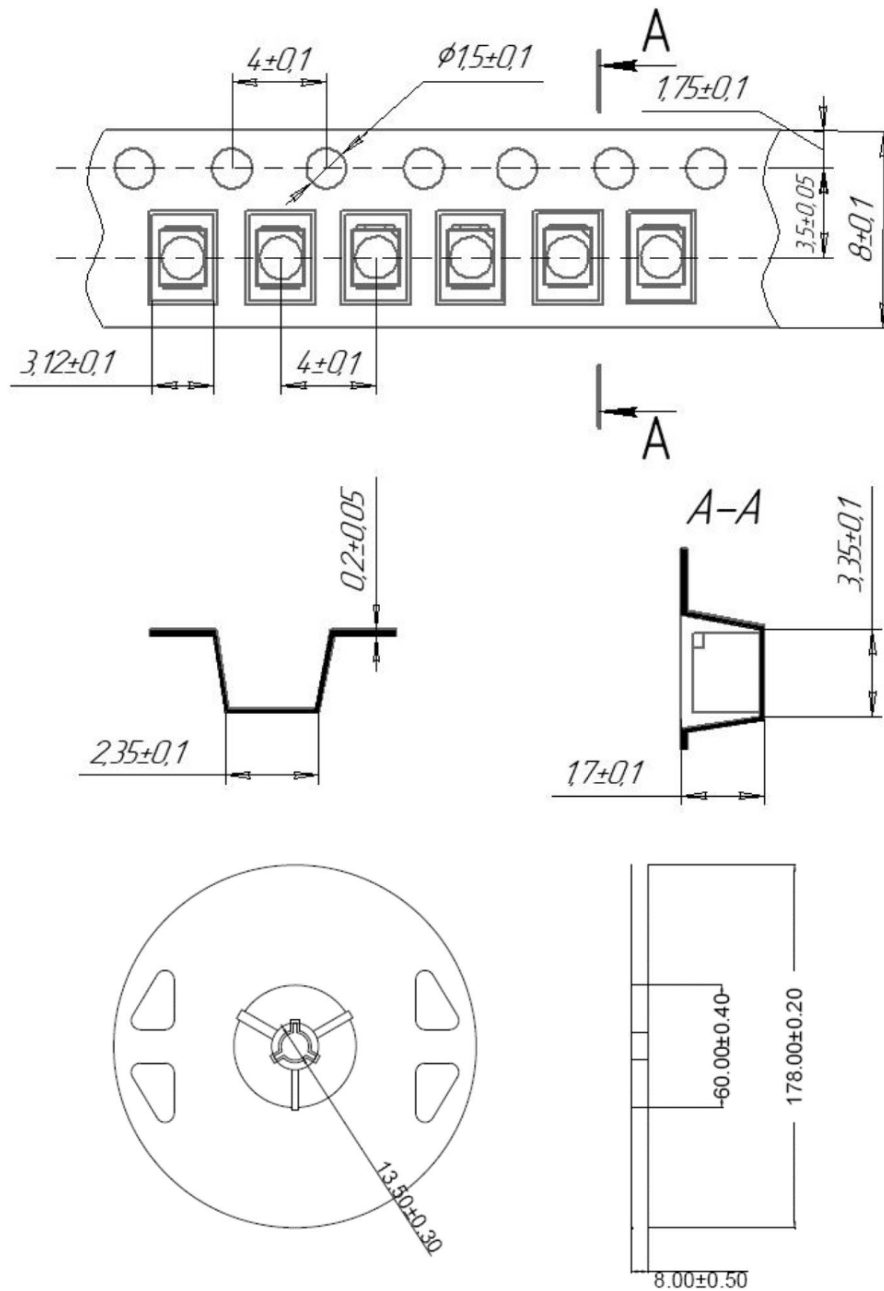
Classification Reflow Profile (JEDEC J-STD-020C)



9111110000.0000 Rev.10 (17.10.19)

**Packaging specifications**

9111110000.0000 Rev.10 (17.10.19)

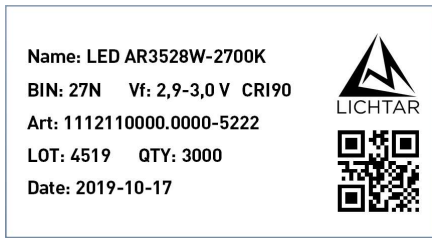

**Notes:**

- 1) Dimensions are specified as follows: mm
- 2) Normal packing quantity: 3000pcs/reel. From 500pcs/reel on special order.

**Information on the content of precious metals**

Gold content in 1000 pcs. LEDs ~ 0.019 g.

Silver content in 1000 pcs. LEDs ~ 0.069 g.

**Marking specifications**


9111110000.0000 Rev.10 (17.10.19)

Name: AR3528W-2700K - LED Series name and color temperature (K);

Art: 1112110000.000-5222 - Unique identification code of the manufacturer (depending on the characteristics of the LED);

BIN: 27N - Color BIN Code (see pages 4...9);

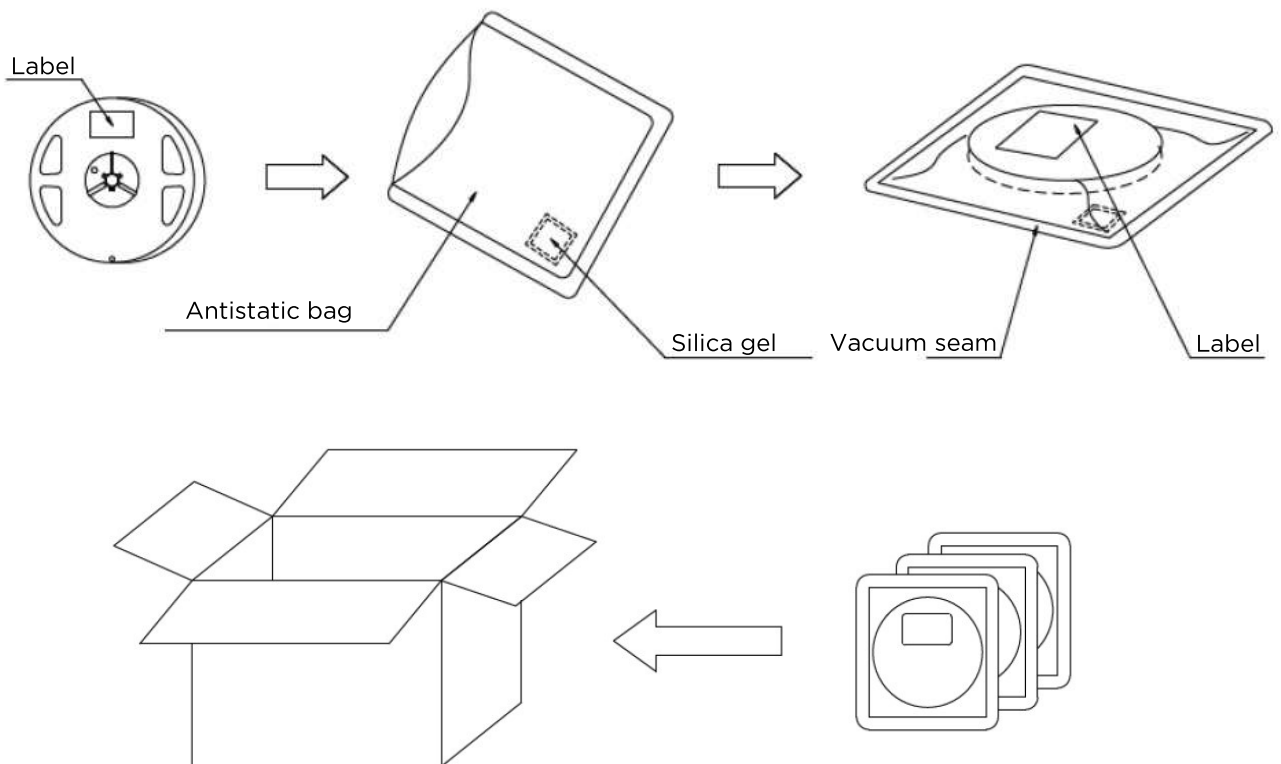
VF: 2.9...3.0 - Voltage BIN (see page 13);

CRI90 - CRI Group name (see page 3);

LOT: 4519 - manufacturer lot number;

QTY: 3000 - quantity of LEDs (pcs/reel);

Date: 2019-10-17 - date of manufacture.

**Antistatic package**

**Reliability Tests**

**Tests and results**

Type of Test	Criterion	Test conditions	Duration	Samples	Suited (%)
Running	Turning on	$T_A=25^{\circ}\text{C}\pm 5^{\circ}\text{C}$ * $I_F=20\text{mA}$	1000 hours	20	100%
Env. test	High temperature	$T_A=100^{\circ}\text{C}\pm 5^{\circ}\text{C}$	1000 hours	20	100%
	Low temperature	$T_A=-40^{\circ}\text{C}\pm 5^{\circ}\text{C}$	1000 hours	20	100%
	Temperature and humidity	$T_A=60^{\circ}\text{C}\pm 5^{\circ}\text{C}$ $\text{RH}=85\%\pm 5\%$	1000 hours	20	100%
	Thermal shock	$10^{\circ}\text{C}\pm 5^{\circ}\text{C}(15\text{min}) <> 100^{\circ}\text{C}\pm 5^{\circ}\text{C}(15\text{min})$	100 cycles	20	100%
	Thermal cycling	$-40^{\circ}\text{C}-25^{\circ}\text{C}-100^{\circ}\text{C}-25^{\circ}\text{C}$ 30min-5min-30min-5min	300 cycles	20	100%
Mechanical test	Resistance to soldering temperature	$255-260^{\circ}\text{C}$ , 8 sec	once	20	100%

Note:

- The test for resistance to soldering temperature is carried out first.

**Criteria for the assessment of validity**

Characteristic	Symbol	Conditions	Evaluation criterion	
			Min	Max
Supply voltage	$V_F$	$I_F=20\text{ mA}$	---	Basic x 1,02
Luminous intensity	$I_v$	$I_F=20\text{ mA}$	Basic x 0,7	---

9111110000.0000 Rev.10 (17.10.19)

### Precautions

1. Do not exceed the rated power.
2. Avoid exposure to static electricity (ESD).
3. Do not allow mechanical impact (pressure, penetration of foreign objects) on the LED lens.
4. The shelf life in the original packaging at a temperature of  $<40^{\circ}\text{C}$  and a relative humidity of  $<95\%$  is 12 months from the date of production.
5. After opening the package, it is recommended to use LEDs for 72 hours.
6. When storing the LEDs in the opened package more than 72 hours before use, perform drying at  $65^{\circ}\text{C}$  for at least 24 hours.
7. Avoid storage in conditions of condensation (below dew point).

9111110000.0000 Rev.10 (17.10.19)